

PRAMA

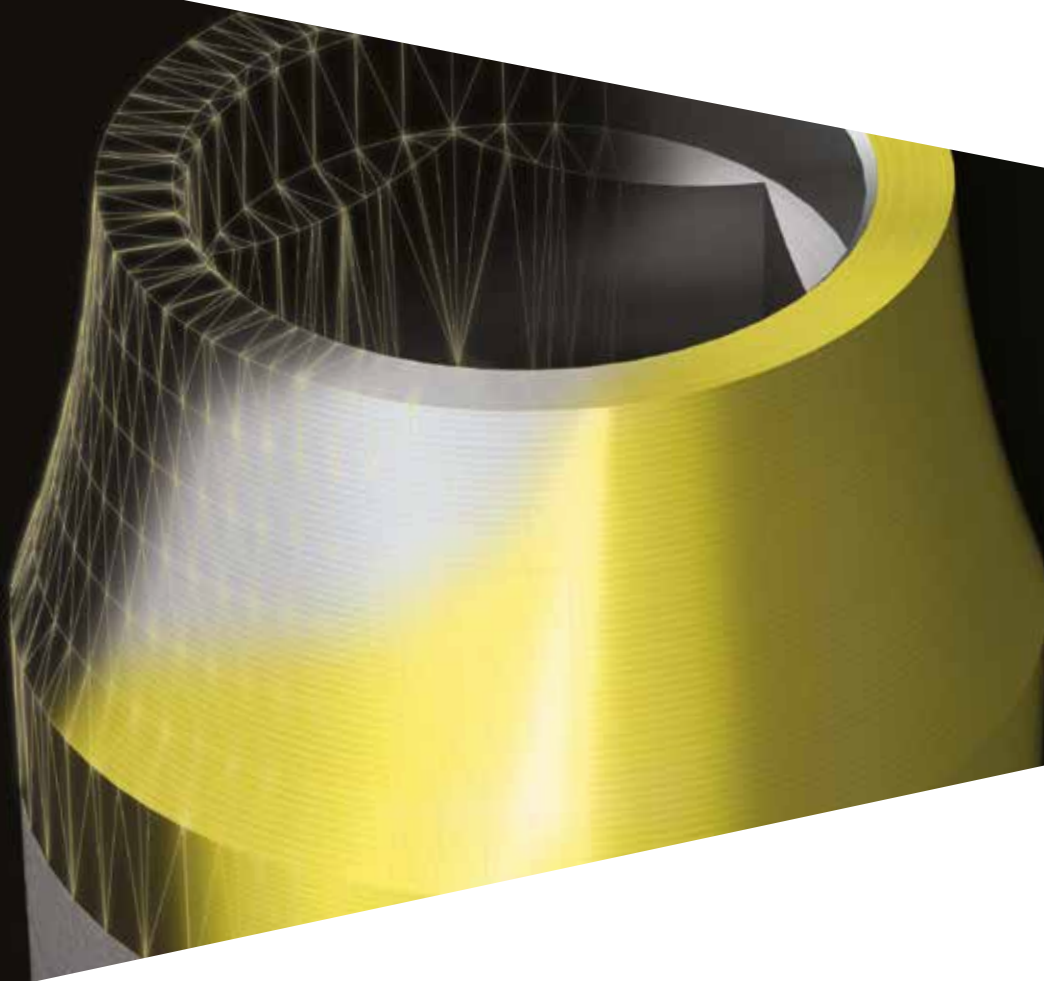

From natural teeth to implantology

The Prama system has been developed in collaboration with Dr. Ignazio Loi, transferring the concepts of the B.O.P.T. technique (Biologically Oriented Preparation Technique) from the prosthesis on natural teeth to the prosthesis on implants. The Prama system offers all the characteristics needed for an implant-prosthesis rehabilitation for the benefit both of hard and soft tissues, which respects their biology and which helps their re-growth and aesthetics.



The Prama implants are available in two versions:

- Standard, with a cylindrical morphology, documented by over 15 years of clinical experience, suitable in all the zones of the oral cavity thanks to its stability and insertion easiness in the mandible;
- “RF” (Root Form), with a tapered morphology specifically studied for the upper jaw and for poorly mineralized bone in which this fixture can achieve the maximum stability, thanks to its structure.

Biologically oriented preparation technique (B.O.P.T.): a new approach for prosthetic restoration of periodontically healthy teeth.

Loi I., Di Felice A.
European Journal of Aesthetic Dentistry 8(2013), 1, 10-23 .

Periimplant tissue remodelling: scientific background and clinical implications.

Canullo L. Cocchetto R., Loi I.
Chapter 8: Abutment Morphology and Peri-Implant soft tissues. Milan, Italy, Quintessence Editions, 2012.

Protesi su denti naturali nei settori di rilevanza estetica: descrizione tecnica B.O.P.T.; Case series report.

Loi I.
Dental Cadmos 2008;76(10):51- 59.



“All the procedures which characterize the B.O.P.T. technique on dental elements have been transferred also to the implantology, achieving the creation of Prama, the fixture originated by the principles of the B.O.P.T. technique in order to simplify the implant prosthodontics. The freedom of choice between tapered or cylindrical morphology and two different surface treatments make the surgical positioning simple and safe. The emergence profile with hyperbolic geometry allows an effective continuity between the implant and the post; the anodic treatment allows a perfect mimetism with the soft tissues. Prama is the implant to reach the prosthetic excellence.”

dr. Ignazio Loi

Case report: implant prosthetic restoration of a frontal incisor with Prama implant



Initial situation: root fracture of the central incisor 2.1.



Frontal sight of the Prama implant after the insertion, with its healing abutment.



Intraoral post-operating RX.



Tissue aesthetics 7 days after surgery.



Healing abutment removal 3 months after surgery; please note the aesthetics of the tissue around the transgingival neck of the implant.



Impression phase.



Temporary crown for tissue shaping, and restoration of both central incisors with composite.



Insertion of the abutment.



Insertion of temporary crown to shape soft tissues.

Prama

The cylindrical morphology of the Prama implants, with 15 years of clinical experience, allows to take advantage of the implant design according to the site and the most appropriate use. In particular, the cylindrical body facilitates the insertion in the mandibular bone, which is often poorly vascularised and highly corticalised. Moreover it guarantees the maximum surface of bone-to-implant contact, for the benefit of the BIC percentage which can be obtained.

The transgingival neck of the Prama implants is characterized by a straight cylindrical section 0.80 mm high, followed by a section with hyperbolic geometry 2.00 mm high, specifically designed in order to guarantee continuity with the post.

The Prama implant is available in three endosseous diameters: 3.80 mm, 4.25 mm and 5.00 mm; the connection diameter is always 3.40 mm: in this way the management of the prosthetic components is simplified and optimised.

The spire of the Prama implant has an asymmetric profile and its thread has a pitch of 1.00 mm and a depth of 0.40 mm. The apex, with its three notches for decompression and clot discharge, guarantees a great penetration in the bone, antirotationality and an excellent primary stability.



Range of the Prama heights

implant Ø	heights
3.80 mm	8.50 mm, 10.00 mm, 11.50 mm, 13.00 mm, 15.00 mm
4.25 mm	8.50 mm, 10.00 mm, 11.50 mm, 13.00 mm, 15.00 mm
5.00 mm	8.50 mm, 10.00 mm, 11.50 mm, 13.00 mm, 15.00 mm

Prama RF (Root Form)

Prama RF is the tapered version of the Prama implant, with which it shares the connection and the transgingival neck. Due to its pure tapered morphology Prama RF is particularly recommended for the insertion in the upper jaw; in the maxillary bone or in a poorly mineralized bone, in fact, the RF implant reaches the maximum stability, thanks to its morphology. The machined surface of the transgingival neck together with the golden colour obtained with a controlled passivation process, facilitates the aesthetics and the re-growth of the soft tissues around it.

The body with hyperbolic geometry which characterizes the Prama RF implants, as well as the cylindrical Prama ones, guarantees continuity with the post connected to it, and the absolute absence of sharp edges as a consequence of it, allows the mucosa to flow on the titanium without obstacles and reach the adaptation profile established by the dentist.

The spire of the Prama RF implant has a triangular profile, its thread has a pitch of 1.50 mm and a depth of 0.40 mm. The markedly rounded apex and the not aggressive thread of this implant make it safe and reliable also in the cases of maxillary sinus elevation.



Range of the Prama RF heights

implant Ø	heights
3.80 mm	8.50 mm, 10.00 mm, 11.50 mm, 13.00 mm, 15.00 mm
4.25 mm	8.50 mm, 10.00 mm, 11.50 mm, 13.00 mm, 15.00 mm
5.00 mm	8.50 mm, 10.00 mm, 11.50 mm, 13.00 mm, 15.00 mm

Surfaces

The Prama and Prama RF implants are available with the ZirTi Gold Machined surface, characterized by a machined transgingival neck, submitted to a particular controlled passivation process which gives to it a golden yellow colour, and by the endosseous body of the implant which is treated with ZirTi surface. The Prama implants are available with fully machined surface.

ZirTi Gold Machined Surface

(Zirconium Sand-Blasted Acid Etched Titanium)

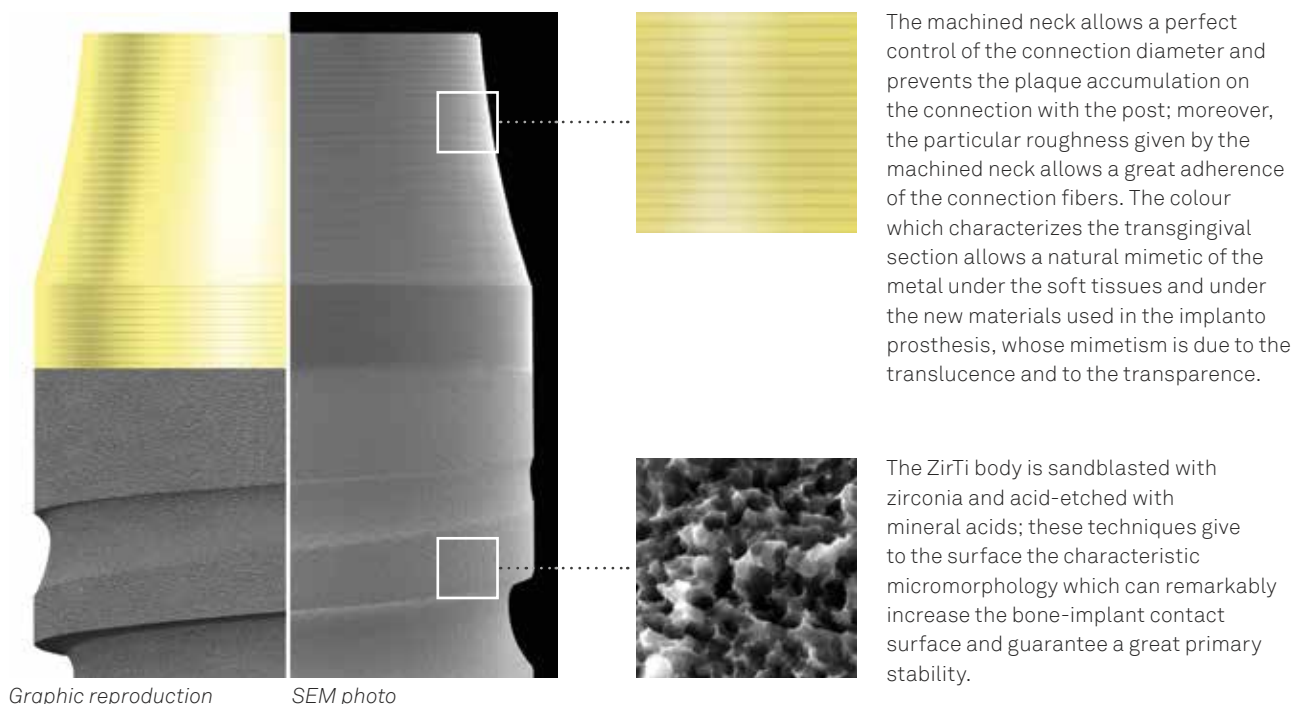

The validity of the ZirTi surface is documented by numerous experimental studies:

Bone healing pattern in surgically created circumferential defects around submerged implants: an experimental study in dog

Rossi F., Botticelli D., Pantani F., Priscila Pereira F., Salata L.A., Lang N.P.
Clin. Oral Impl. Res. 23, 2012; 41–48. doi: 10.1111/j.1600-0501.2011.02170.x

Osteogenesis at implants without primary bone contact – An experimental study in dogs

Sivolella S., Bressan E., Salata L.A., Urrutia Z.A., Lang N.P., Botticelli D.
Clin. Oral Impl. Res. 23, 2012; 542–549 doi: 10.1111/j.1600-0501.2012.02423.x

Bone-healing pattern at the surface of titanium implants: an experimental study in the dog

Rossi F., Lang N.P., De Santis E., Morelli F., Favero G., Botticelli D.
Clin. Oral Impl. Res. 00, 2013; 1–8 doi: 10.1111/clr.12097

Hard and soft tissue changes around implants installed in regular-sized and reduced alveolar bony ridges. An experimental study in dogs

Baffone G., Lang N.P., Pantani F., Favero G., Ferri M., Botticelli D.
Clin. Oral Impl. Res. 00, 2013; 1–6 doi: 10.1111/clr.12306



Bone healing around an implant with ZirTi Gold Machined surface.

Image from Sweden & Martina archives.

Machined surface

The Prama implants are also available with fully machined surface.

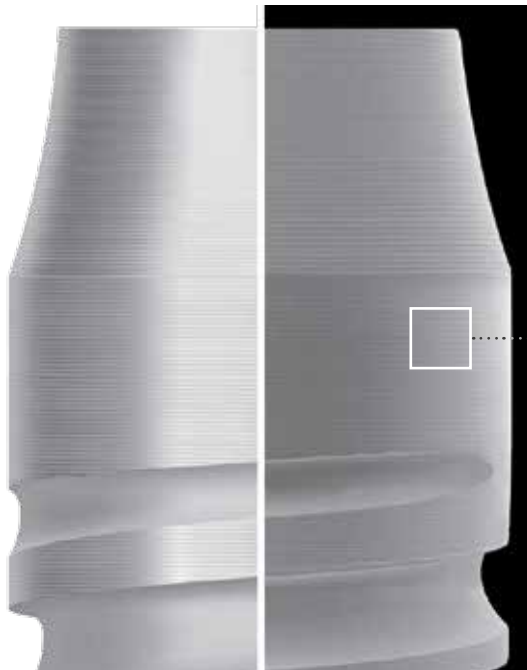

Graphic reproduction

SEM photo

The machined neck allows a perfect control of the connection diameter and prevents the plaque accumulation on the connection with the post, moreover, the particular roughness given by the machined neck allows a great adherence of the connection fibers. The roughness of the machined surface is suitable for a correct osteointegration process, as documented by 30 years of clinical evidence.

The presence of the machined surface on all the coronal part of the implant allows freedom in the management of the depth of insertion of the fixture, depending on the single clinical situation.

Behavior of SaOS-2 cells cultured on different titanium surfaces

Postiglione L., Di Domenico G., Ramaglia L., Montagnani S., Salzano S., Di Meglio F., Sbordone L., Vitale M., Rossi G.
Journal of Dental Research, 82 (9): 692-696, 2003

Adhesion pattern and growth of primary human osteoblastic cells on five commercially available titanium surfaces

Passeri G., Cacchioli A., Ravanetti F., Galli C., Elezi E., Macaluso G.M.
Clinical Oral Implant Research 21: 756-765, 2010

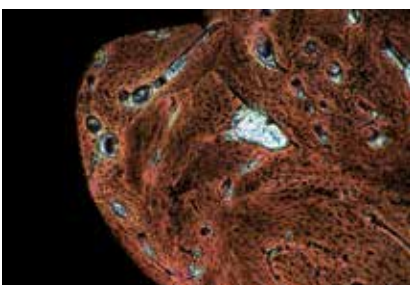

Bone healing around a machined implant.
Image courtesy of dr. Daniele Botticelli.

Connection

The Prama implants are available in three different nominal diameters, 3.80 mm, 4.25 mm and 5.00 mm, joined by a single connection diameter, 3.40 mm. In this way the surgical and prosthetic management is simplified, as well as the storehouse of prosthetic components needed by surgeon and laboratory.



Collex

The Prama implants have the Collex connection, already present in the Premium, Kohno and Shelta systems. The presence of a prosthetic support collar, positioned in the inner part of the connection, guarantees a great prosthetic stability and allows the connection of the implant through the patented drivers Easy Insert, for a safe insertion *in situ* with mountless technique. The internal connection hexagon is synonym of high prosthetic stability and lends a great resistance to the masticatory loadings to the prosthetic structure. The Prama implants have been submitted to fatigue dynamic resistance tests of 5.000.000 cycles.



An Evaluation of New Designs in Implant-Abutment Connections: A Finite Element Method Assessment.

Covani U., Ricci M., Tonelli P., Barone A.

Implant Dentistry Volume 22, Number 3 2013, pagg. 263-267.

Contracone seal

One of the key factors in determining the success of an implant prosthetic rehabilitation is the absence of bacteria infiltrations; to achieve this aim there must be no spaces between the platform of the implant and the abutment's edge, where bacteria could penetrate and give rise to anaerobic proliferations which are dangerous for the peri-implant tissues.

Sweden & Martina have patented a particular micromechanical process which makes conical both the implant's edge and the post's one: in this way a mechanical barrier is created, which guarantees a peripheral seal that is able to limit the access of bacteria and to preserve the peri-implant tissues against possible inflammations.

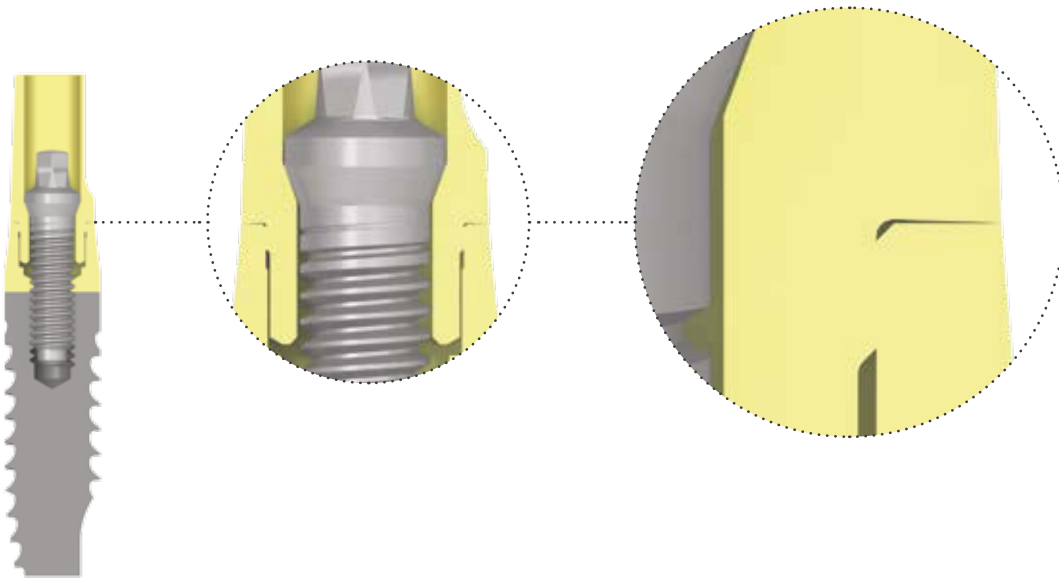

As all the Sweden & Martina systems, also the Prama implants are characterised by the Contracone seal, which is the result of the slight conicalness both on the coronal margin of the implant and on the margin of the post which leans against it. In this way a seal is created, and it hinders the bacterial infiltrate, preserving the peri-implant tissues against possible inflammations.

Microbiological assessment of the implant-abutment interface in different connections: cross-sectional study after 5 years of functional loading.

Canullo L., Peñarrocha-Oltra D., Soldini C., Mazzocco F., Peñarrocha MA, Covani U.
Clin. Oral Impl. Res. 00, 2014, 1–9 doi: 10.1111/ctr.12383.

Fixation screw with Full Head technology

The fixation screw for the Prama posts have been specially studied in order to allow a wide freedom of angled posts personalization. As a matter of fact the head of the screw is full and presents an external hexagon of reduced dimensions compared to one corresponding fixation screw with internal hexagon. The head of the screw presents a conical support which improves the prosthetic tightening without impeding its removal.

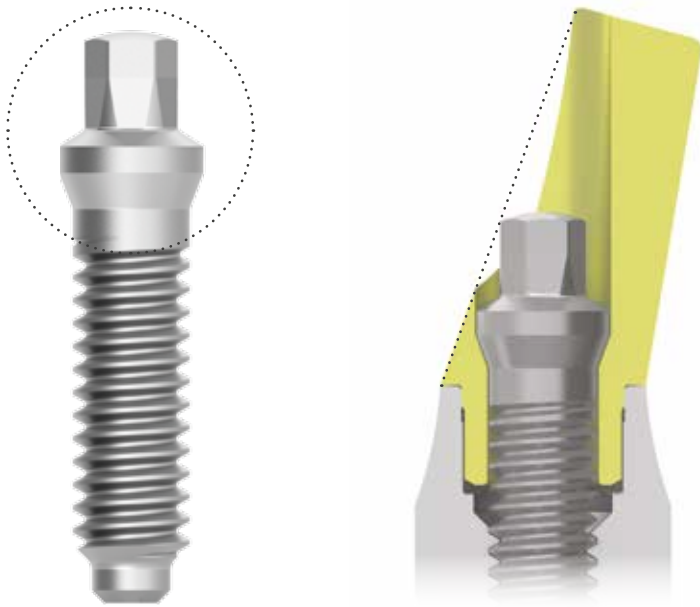

The Prama screws, thanks to the Full Head technology, occupy less space than the traditional fixation screws, making possible to personalise the individualised solutions in a better way especially in case of angled posts.



For the screwing and unscrewing manoeuvres of this particular fixation screw, dedicated screwdrivers are available, made of steel for surgical use: they are available in three different lengths to be used with torque-control ratchet, and one screwdriver with right angle shank.

Pre-made posts

The Prama angled and straight pre-made posts have been designed together with the screws with Full Head technology. Furthermore, a fixation screw with conical support and internal hexagon guide is available: this screw results particularly useful when the post total height needs to be consistently reduced, because it doesn't leave any residual space for the cement to insert.

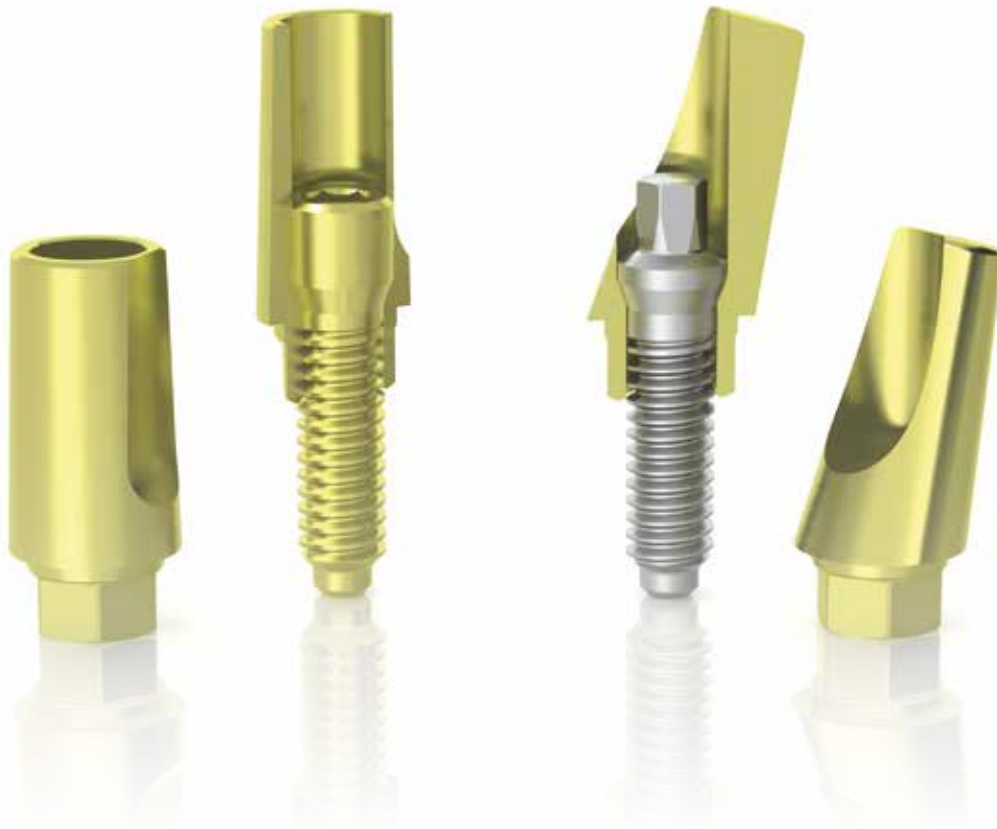

The pre-made posts have been designed specifically to grant continuity with the transgingival neck with Prama hyperbolic geometry. This absence of sharp edges will allow to the mucosa to flow on titanium without obstacles and to reach the adaptation profile established by the prosthodontist; moreover, it will facilitate the closure of the prosthetic crown in any portion of the transgingival section.



Ergonomic, small and compact surgical kit

The Prama surgical kit is small and practical and it includes all the instruments needed for the surgical preparation phase of the insertion sites of the standard Prama implants and the RF; moreover it includes the screwdrivers needed for the rehabilitation phase. The kit contains also the Easy Insert drivers, for a correct insertion of the implants and the “REPLY” replies, made of Gr. 5 titanium, very useful for a proper preparation of the site for the Prama RF tapered implants.



REPLY: replies for RF tapered implants

The “REPLY” replies are made of Gr. 5 titanium and reply the morphology of the final drills of the related Prama RF tapered implants. They are useful to verify the depth of the preparation hole made with the final drills, and to verify the axis of the preparation made with the drill.



On the conical section, the replies has some notches far from each other 1 mm to verify the gingival thicknesses. The part of the reply intended to be inserted in the bone is characterized by anodic treatment with the colour related to the implant diameter, following the same colour code of the implant system: in this way its use is even more simple and intuitive.

Mountless surgical procedure

The surgical procedure of insertion is extremely simple. The implant does not require any mounter because it can be engaged directly inside the connection by practical Easy Insert drivers designed to guarantee a safe grip, to **prevent deformations to connections** and at the same time to allow easy removal from the implant well. Easy Insert drivers are available with long or short right angle shank, and with hexagonal connector for dynamometric ratchet.

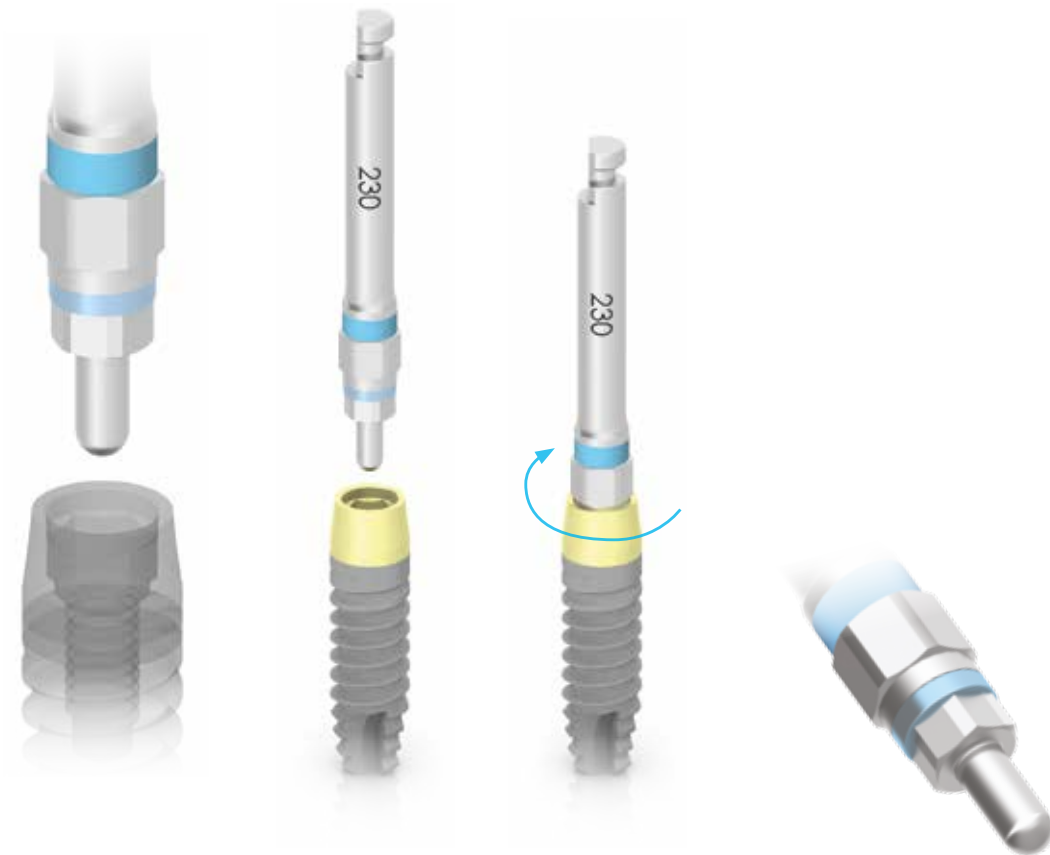

The special design of the Easy Insert drivers prevent any deformations of the implant connection, since the driver's faces are the ones in contact with the implant well, instead of the driver's edges, guaranteeing in this way stability and very high prosthetic precision.

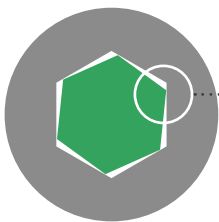

..... Traditional driver section

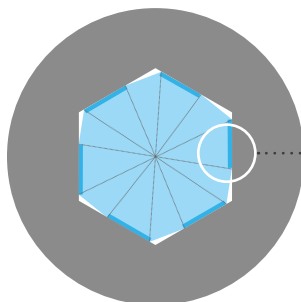

..... Easy insert driver section

Wide range of prosthetic solutions

Laboratory components

On all the Prama and Prama RF implants it is possible to take an accurate impression thanks to the Pick-up transfers, characterized by anodic treatment following the colour code of the system; in the case of scarce oral opening of the patient Pull-up transfers in PEEK are available, with the practical tabs systems which “click” directly on the implant connection without requiring any screws.

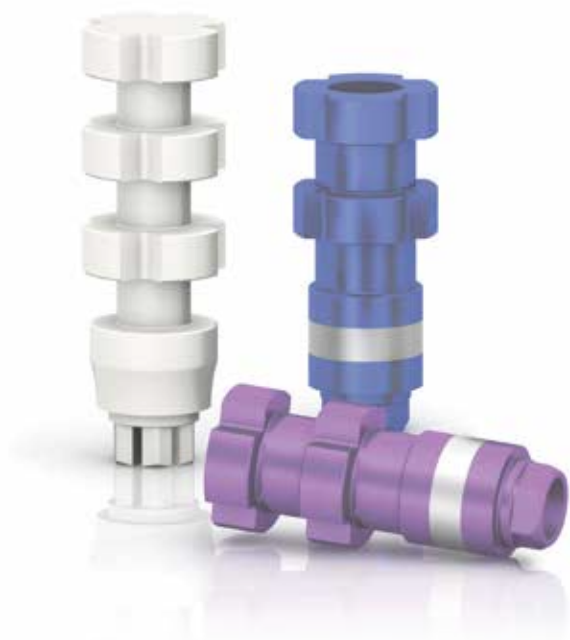

Prama analogs are also available, produced with the same machines that produce the implants; this ensures a real guarantee of precision from the point of view of tolerance and fidelity in the reproduction of the clinical situation and of the connection of the transgingival neck of the implants.



Transfers and analogues characterized by anodic treatment according to the colour code to facilitate recognition of the implant diameter and laboratory phases.

Other prosthetic components

The connection platform of the Prama implants is the same of the Premium Kohno Ø 3.30 mm implants, therefore these two systems have some prosthetic components in common. The Premium Kohno prosthetic components which can be used on Prama implants are only the ones with straight emergence profile, since the components with anatomical emergence would not allow to obtain an harmonious continuity between the implant neck and the post, not respecting in this way the principles of the B.O.P.T. technique on which base the Prama system has been designed. Please refer to the Prama catalogue for the detail of the single items and the related measures.

Healing abutments



Posts for screwed temporary prostheses



Millable posts



Prosthesis on intermediate abutments



Castable posts



PLAIN abutments



Locator abutments for overdentures*



Ball attachments for overdentures



* Locator abutments are medical devices manufactured and patented by Zest Anchors, Inc., 2875 Loker Avenue East, Carlsbad, CA 92010 USA. Locator is a registered trademark of Zest Anchors, Inc. The European Agent for the purposes of MDD 93/42/EEC is Ventura Implant and Attachment Systems, 69 The Avenue, Ealing, London W13 8JR, England.



rev. 03-16



Sweden & Martina S.p.A.

Via Veneto, 10
35020 Due Carrare (PD), Italy
Tel. +39.049.9124300
Fax +39.049.9124290
info@sweden-martina.com
www.sweden-martina.com

Sweden & Martina Mediterranea S.L.

Sorolla Center, Oficina 801
Avda Cortes Valencianas 58, 8pl
46015-Valencia, Spain
Tel. +34.96.3525895
Tel. 900993963
info.es@sweden-martina.com

Sweden & Martina Deutschland GmbH

Rupert-Mayer-Straße 46
D - 81379 München
Germany
Hotline 08001827699
info.de@sweden-martina.com

Sweden & Martina Inc.

c/o DCI Management
301 Pleasant St.
Abbottstown, 17301 PA, US
Toll free 844-8MARTINA
844-862-7846
info.us@sweden-martina.com

The implants, standard prosthetic components and surgical instruments contained in this brochure are Medical Devices and are manufactured by Sweden & Martina S.p.A. They conform to the ISO 9001 and ISO 13485 standards and are certified with the CE Mark (Class I) and CE 0476 mark (Class IIA and class IIB) in compliance with European Medical Device Directive No. 93/42 and European Directive No. 2007/47/CE.

We have met the good manufacturing standards (cGMP) set forth by many countries worldwide, including the United States FDA.



We have met the good manufacturing standards (GMP) set forth by many countries worldwide, including the United States FDA.

The contents are updated at the time of publication. Check with the company for any subsequent updates.

All trademarks herein are the property of Sweden & Martina S.p.A. unless otherwise indicated.
This material is intended for laboratories and clinicians and is not intended for patient distribution.
This material is not to be redistributed, duplicated, or disclosed without the express written consent of Sweden & Martina S.p.A.
For additional product information, including indications, contraindications, warnings, precautions, and potential adverse effects, see Sweden & Martina S.p.A. website.